

PRODUCT CARD			
PRODUCT MODEL	MSBP0125A01HV2-TM1		
PRODUCT WEIGHT (Kg)	~22		
DESCRIPTION	125A 01 UPS NONE ANALYZER INPUT-OUTPUT=3 POLE BY PASS=4 POLE		
FEATURES			
KEY TYPE	THERMAL MAGNETIC CIRCUIT BREAKER	UPS QUANTITY	1
POWER ANALYZER	NO	POWER LAMP.	YES
BRAND	CHINT		

SINGLE LINE DRAWINGS

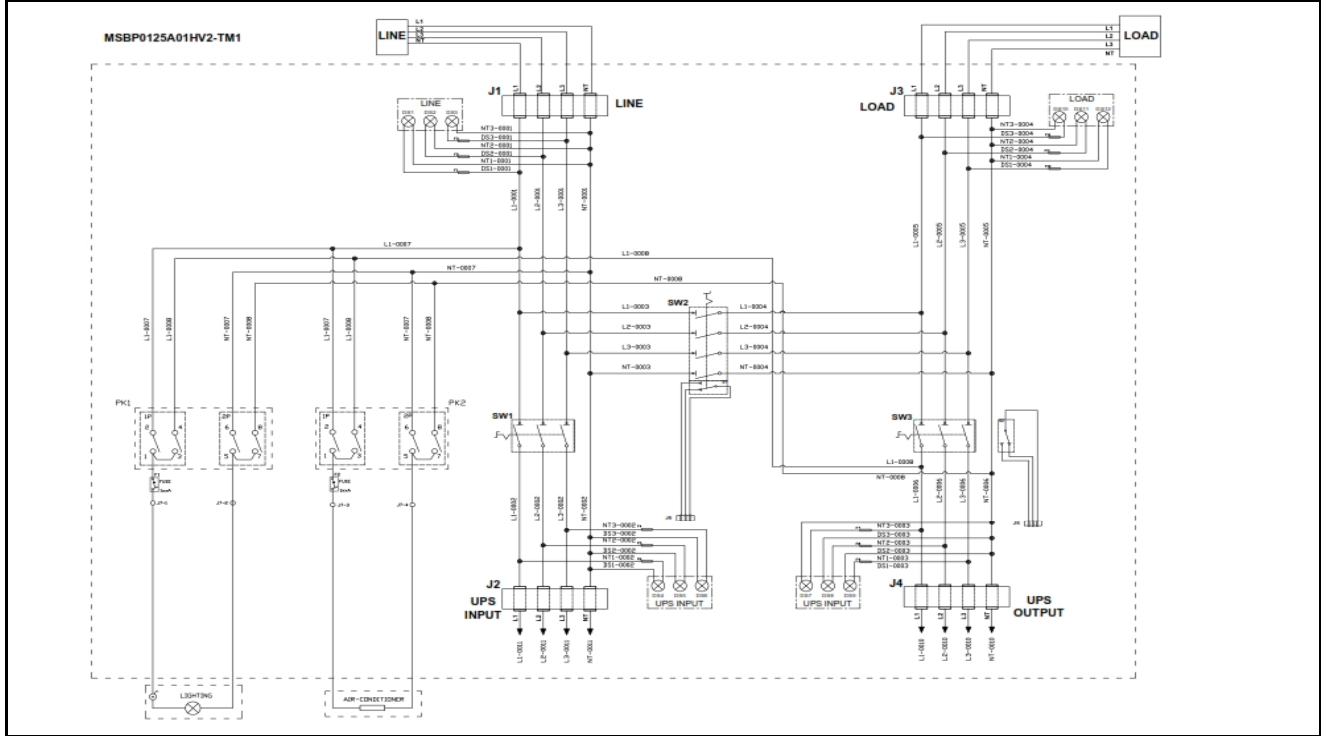

PANEL

PANEL CODE	MKSBP0007	PANEL WEIGHT(Kg)	
SIZE(mm)(WxHxD)	500 x 600 x 200	ASSEMBLY SIZE(mm)(WxHxD)	568 x 623 x 222
USED RECORDS	PG 16	1 PIECE	PG 29
			4 PIECE

