



ute
electronic gmbh & co.kg

ATS-16 HV

Automatic Transfer Switch 16A / 230Vac

USER MANUAL

SAFETY

Intended use

The ATS-16 HV device serves as a power source selector to provide improved power supply for connected loads.

ATS-16 HV can be operated in the 1 phase mains. The device is in compliance with all relevant safety regulations concerning information technology equipment, including electronic machines for use in an office environment.

Warning

- The User or Operator may intervene in the operation of the ATS-16 HV provided that the instructions laid out on below connection.

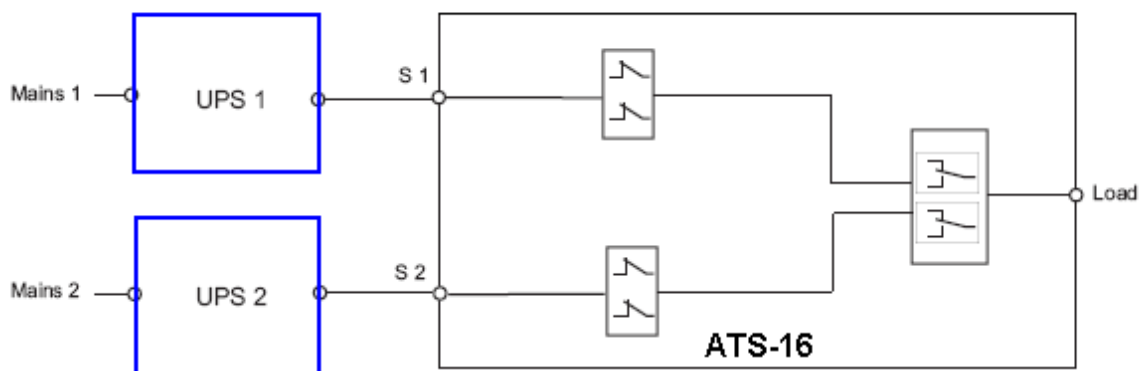

Supply system with ATS

ATS system with two feeding UPS devices upstream

- The Installation of the ATS-16 HV may only be carried out by qualified technical personnel.
- Even when all switches and interrupters are open, hazardous voltages are present within the ATS-16 HV; any operation that requires cases to be opened and/or removed may be carried out by authorized technical personnel only.

Safety notices

Danger

Carefully read the following safety notices! Failure to observe the instructions may danger your life, your health, the reliability of your device or the security of your data.

- Transport the unit only in suitable packaging.
- If the equipment is moved from a cold environment to the operating room, condensation may occur. Before you switch on the equipment it must be absolutely dry.
- The equipment must be installed in accordance with the environment conditions specified as, Operating temperature: 0 to 40°C, Operation humidity: 20% to 85% (no condensing).
- ATS-16 HV devices are not intended to operate with isolated neutral. Neutral connector must be present.
- Lay all cables so that nobody can stand on them or trip over them.
- For pluggable equipment, the socket-outlet shall be installed near the equipment and shall be easily accessible. The plug on the power supply cord is intended to serve as the disconnecting device.
- Make sure that no objects get inside the device.



- Do NOT connect equipment that will overload the ATS-16 HV. (for example: laser printers).
- The sum of the leakage currents of the ATS-16 HV does not exceed 3.5mA. Earth connection is essential for ATS-16 HV before connection supply.
- Data transmission lines should NOT be connected or disconnected during a thunderstorm.

Emergency

Danger

The supply to the load may be interrupted by opening all the switches.

DO NOT use WATER to extinguish any fires that may occur in the area in which the ATS-16 HV is installed.

Radio Interference

The ATS-16 HV is a Radio Interference Class C1 product (IEC62310-2).

The device may cause radio interference. DO NOT place it near devices which are especially susceptible to electromagnetic interference.

Repackaging

DO NOT remove air from the packaging.



OPERATING INSTRUCTIONS

Introduction

This manual contains information regarding the installation, operation and use of the ATS-16 HV.

It is advised that this User Manual be consulted before installation of the equipment, which operation shall only be carried out by qualified personnel.

Device Overview

The ATS-16 HV is available voltage level 220/230/240Vac,
Nominal current: 16Amp.

PREPARATION FOR USE

Delivery and Storage

The goods have been checked thoroughly before dispatch. On receipt check the packaging and ensure that the contents are undamaged. Any damage or missing parts must be reported to the supplier as soon as possible.

Inventory List

- ATS-16 HV module
- 2 pluggable input power cable (p/n: 108-00140-xx)
- Bracket kits (for rack mounting and vertical mounting)

NOTE:

1. An approved power cord greater or equal to H05VV-F, 3G, 0.75 mm² must be used.
2. User Manual will be file sending only, not make printing and put it in accessory kit.

Storage

Storage temperature:-25 to 70°C,
Storage humidity: from 10% to 90%.

Handling

The equipment must be handled with care, damage may be caused if dropped or subjected to severe impact.

Environmental Conditions

The ATS-16 HV must be installed as rack mount or on a level and even surface and in an area protected from extremes of temperature, water and humidity and the presence of conductive powder or dust.

DO NOT stack units and do not place any objects on top of a unit.

Rack Mounting

Taking into consideration to mount the ATS-16 HV into a cabinet, it is necessary that chosen cabinet be capable of supporting the unit with corresponding rails or angels.

ATS-16 HV scope of supply contains two angels for fixing the ATS-16 HV into a 19 inch rack or into a cabinet with 19 inch inner design.

Also ATS-16 HV vertical mounting is possible.

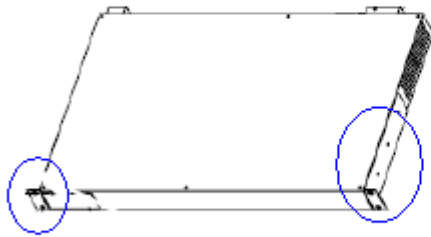

Rack Mounting

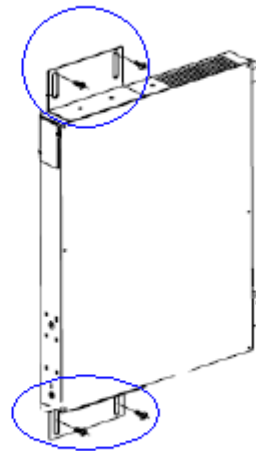

Vertical Mounting

Dimensions of area

It is necessary to leave a minimum space of a few centimeters around right side, left side and rear side to allow a flow of air and to provide access to interface.

INSTALLATION

Configuration of the ATS-16 HV system

The ATS-16 HV provides high reliability supply by switching the load to one of two possible power suppliers.

Primarily these two supplies are UPS devices with sinusoidal output only. These UPS must operate with double conversion principle.

Technical Data

Block Diagram

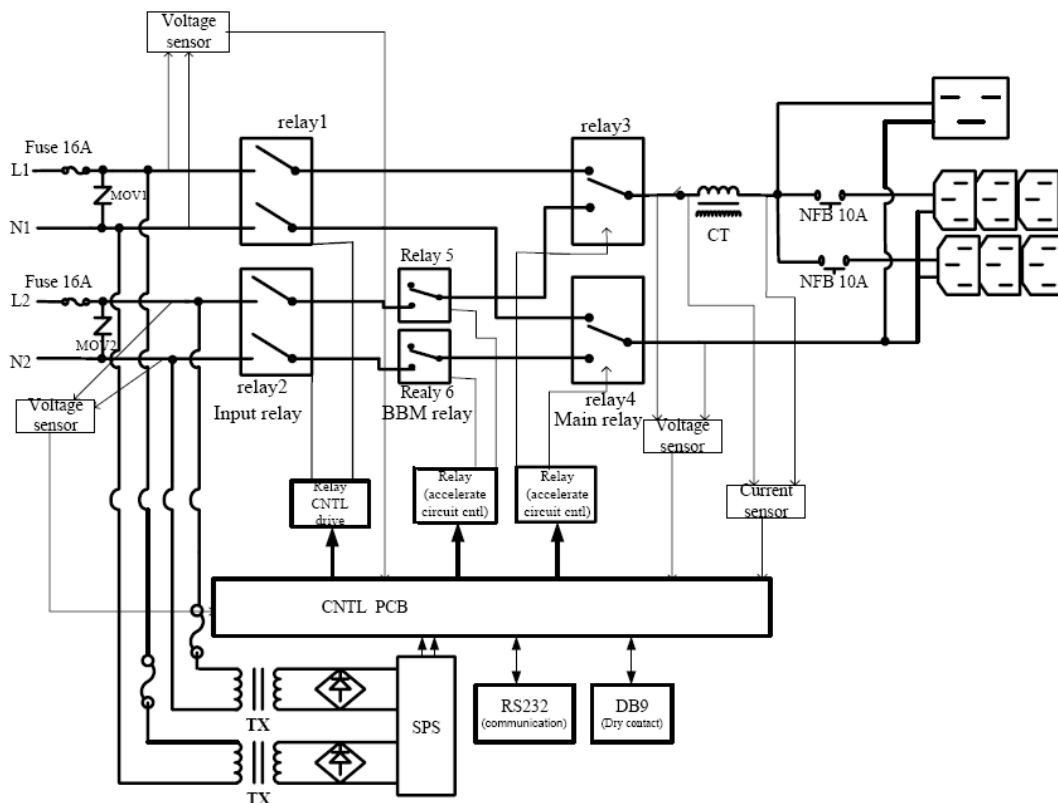



ATS-16 HV Technical Data

Input features

Item	Specification	Remark
Nominal input voltages	230 Volts (220/230/240 selectable)	Default: 230Vac
Working range	160 ~ 290Vac	
Input voltage acceptance window	Nominal voltage +/- 12% ~ +/- 20%	Adjustable (Default: +/- 12%)
Input voltage low comeback	Input voltage low loss volts +10V	
Input voltage high comeback	Input voltage high loss volts -10V	
Nominal current	16 Amp	
Nominal frequency	50/60Hz selectable	
Input frequency range	Nominal frequency +/- 15%.	

Output features

Items	Specifications	Remark
Output voltage	Same as input voltage	
Output frequency	Same as input (50 /60 Hz)	
Output current	16 Amps	
Typical transfer time	<10ms	
Max. transfer time	15m second	

Interface

Items	Specifications	Remark
Inlet	IEC 320-C20x 2	Power Cord: p/n 108-00140-xx
Outlet	IEC 320-C19 x 1 IEC 320-C13-3 x2	
EPO active	Output NOT supplied.	



Communications:

A. RS232 (DB-9, pin type)

PIN No.	Definition
PIN 2:	RX
PIN 3:	TX
PIN 5:	GND

B. Dry Contact (DB-9, pin type)

Pin No.	Description	Open State	Close State
Pin 1	Over temperature signal	Normal	Over Temperature
Pin 2	Not used		
Pin 3	Not used		
Pin 4	Source 1 status signal	Source 1 is fail	Source 1 is ok
Pin 5	Common		
Pin 6	Not used		
Pin 7	Over load signal	Normal	Over load
Pin 8	Source 2 status signal	Source 2 is fail	Source 2 is ok
Pin 9	Summary alarm signal	Normal	Alarm occurred

Mechanical Features

Items	Specification	Remark
Dimension	W = 430mm D = 315mm H = 44mm (1U)	
Weight	Approx. 8kg	
Packaging sizes	W = 585mm D = 425mm H = 184mm	
Color	Silver	RAL 9006
Material	Metallic Case	
Structure	Rack Mount Unit (1U) Vertical mount (0U)	

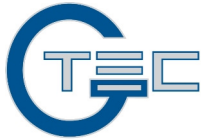

Environment

Items	Specifications	Comments
Operating temperature	0 to 40 °C	
Storage temperature	-25 °C to 70 °C Continuous	
Storage humidity	10% to 90%	
Operation humidity	20%to 85% No condensing	
Operation Altitude	≤ 1000m	
Audible noise	25dBA (max.)	Buzzer OFF
Cooling	Natural Cooling	
IP Protection	IP 30	

Safety Standards
Meet IEC60950-1.

EMC Standard:

EMI	IEC62310-2, C1	
EMS	IEC61000-4-2 level 3	
	IEC61000-4-3 level 2 (Lab.)	
	IEC61000-4-4 level 2	
	IEC61000-4-5 level 3	
	IEC 61000-2-2 LF Immunity	
	IEC61000-4-6 level 2 (Lab.)	
	IEC61000-3-2 Harmonic (Lab.)	
	IEC61000-3-3 Flicks	

Overload Capability:

<p>105%~125%(20A): 45sec, Complete Protection by s/w control for input relay <u>be</u> open. Inhibition algorithm won't be active.</p>
<p>126%~150%(24A): 27sec, Complete Protection by s/w control for input relay <u>be</u> open. Inhibition algorithm won't be active.</p>
<p>151%~210%(33.6A): 5sec, Complete Protection by s/w control for input relay <u>be</u> open. Inhibition algorithm won't be active.</p>
<p>211%~300%(48A): 2sec, Complete Protection by s/w control for input relay <u>be</u> open or input FUSE will be open according to its characteristic. Inhibition algorithm will be active.</p>
<p>Output short-circuit: Complete Protection by input FUSE <u>be</u> open according to its characteristic. (With FUSE holder accessible).</p>

External Protection and Isolation Devices

External devices for the protection of cables and for isolating the ATS-16 HV and UPS external to the devices shall be installed upstream and downstream of the equipment. Select and configure the isolating device upstream according with ATS-16 HV MCB input 16Amp breakers.

Disconnecting devices must be provided in building installations and other locations.

All protection devices (circuit breakers and fuses) placed upstream of the ATS-16 HV input and downstream to ATS-16 HV output line have to be installed by the personnel for the protection of both the cables and the equipment and in coordination with both ATS-16 HV input protection (fuses) and ATS-16 HV overload capacities.

WARNING

If ATS-16 HV overload capacities are overcome the unit will unsupplied the output load. Depending on overload characteristic the ATS-16 HV either will trip the input fuses or drive only internal power relays to the open position.

Front Panel

The following figure shows the front of the ATS-16 HV with its LED display, interfaces.

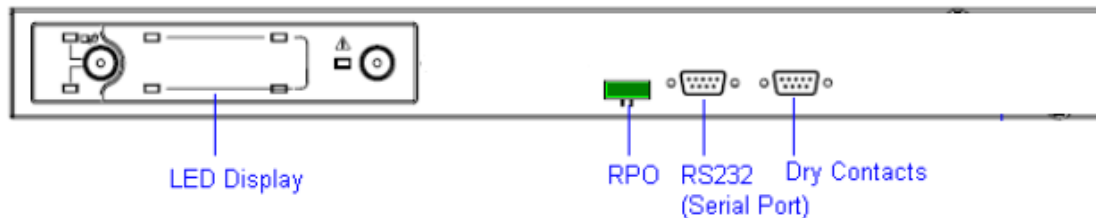

Rear Panel

The following figure shows the back of the ATS-16 HV with its connectors, terminals and interfaces.

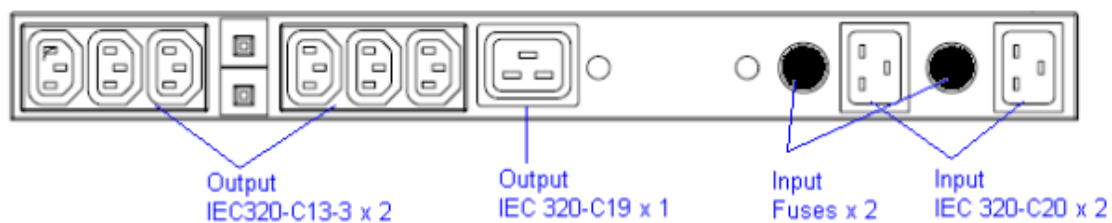

Operating Panel

In the following figure you can see the front panel of the ATS-16 HV.

Most functions of the ATS-16 HV are driven by an internal control.

From the operating panel a priority setting can be made to prefer a mains source. The state of the relay group is displayed with several LEDs.

Please see more detail operation information in following table.

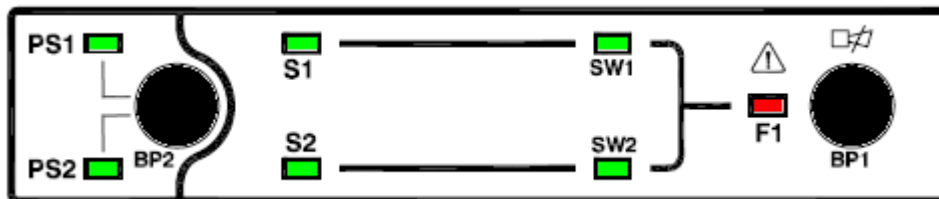

LEDs and Push Buttons of the Operating Panel	
LED PS1 (Preferred Source Indication)	LED PS1 ON (GREEN): Input source 1 is selected as the preferred source (LED PS2 will be OFF when PS1 is selected.)
LED PS2 (Preferred Source Indication)	LED PS2 ON (GREEN): Input source 2 is selected as the preferred source. (LED PS1 will be OFF when PS2 is selected.)
PUSH BUTTON - BP2 (Selection button for Preferred Source)	(Default) PS1 is default preferred input source from factory setting before shipping. Each push for 3 seconds will change the preferred source selection. Note: <ol style="list-style-type: none"> 1. In normal operation, output power is always supplied from the selected preferred source. 2. If the preferred source is abnormal, ATS will automatically transfer to the other source until the preferred source of voltage is back within preset tolerance. 3. If both of the sources are abnormal no voltage is transferred to the output.
LED S1 (Source S1, Line status LED)	LED GREEN: Input source 1 is OK LED FLASH: Input source 1 voltage / frequency is out of range. LED OFF: Input source 1 failure (no power on source)
LED S2 (Source S2, Line status LED)	LED GREEN: Input source 2 is OK LED FLASH: Input source 2 voltage / frequency is out of range. LED OFF: Input source 2 failure (no power on source)
LED SW1 (Output power state LED)	LED SW1 ON (GREEN): load is powered by input source 1. LED SW1 OFF: load is not powered by input source 1.
LED SW2 (Output power state LED)	LED SW2 ON (GREEN): load is powered by input source 2.. LED SW2 OFF: load is not powered by input source 2.
LED F1 (Fault LED)	LED F1 ON (RED): Fault detected: <ul style="list-style-type: none"> - Overload fault - Output short circuit - Input Source relay fault - EPO active LED F1 OFF: normal operation (no fault)
PUSH BUTTON BP1 (Buzzer ON/OFF)	Each push for 1 second will change between Buzzer ON and Buzzer OFF.
PUSH BUTTON - BP1 with BP2 (Fault release)	Each push for 3 seconds of BP1 and BP2 together will release a fault (you must clear the fault conditions first).



Description of the system

The 2-pole ATS-16 HV is a two ways, single phase automatic switch powered by two independent synchronous or asynchronous AC power supply sources.

The ATS-16 HV makes a rapid switch from one source to the other in the event of a fault to the power supply used to power the load.

One of the two sources can be designated as the preferred power supply, to which the ATS-16 HV will transfer the load. It remains there until different designations or faults require it to be switched to the other source.

The ATS-16 HV is fitted with a block diagram with LED indicators, capable of providing all information concerning equipment operation status, together with the power source priority selection button BP2 enable trained operators to make full use of the apparatus.

Features:

- Break Before Make transfer mode.
- Back feed protection (according EN62310-1).
- Complete protection for overload and short-circuit. (With FUSE Holder Accessible).
- Redundant power supply. (From input Source 1 and Source 2).
- AC source detection (voltage and current detection).
- Output detection (current detection).
- LED display.
- EPO contact is integrated
- Different setting to adjust the voltage failure sensing level (+/- 12% ~ +/- 20%). (Default setting: Nominal voltage +/- 12%).
- Protection: IP30.
- ON/OFF for Buzzer
- Selectable Nominal Frequency
- RPO active (open): output not supplied.



Manual Switch ON Procedures

First Switch on from Source A

- Check that all switches are OFF and check the EPO status.
- Input the mains for source A.
- Wait for several seconds until the logic is enabled and the LEDs on the display are switched ON.
 - Priority LED PS1 or PS2 depending on the default setting.
 - LED S1
 - LED SW1
- Input the mains for source B.
- The following LEDs are illuminated:
 - Priority LED PS1 or PS2 depending on the default setting.
 - LED S1
 - LED S2
 - LED SW1 or SW2 according to the primary source

First Switch on from Source B

- Check that all switches are OFF and check the EPO status.
- Input the mains for source B.
- Wait for several seconds until the logic is enabled and the LEDs on the display are switched ON.
 - Priority LED PS1 or PS2 depending on the default setting.
 - LED S2
 - LED SW2
- Input the mains for source A.
- The following LEDs are illuminated:
 - Priority LED PS1 or PS2 depending on the default setting.
 - LED S1
 - LED S2
 - LED SW1 or SW2 according to the primary source

Switch OFF

Warning

When this procedure is carried out the load is no longer supplied by the ATS-16 HV.



Troubleshooting

If problems should occur, please check the following points before contacting the responsible customer service representative:

- Is the mains voltage present at the ATS-16 HV input?
- Has one of the two input fuses tripped or open?

If you contact the responsible customer service representative, please have the following information ready:

- Device information (model name and serial number)
- An exact description of the problem (what loads are being operated, does the problem occur regularly or sporadically, etc.)

Rectification of errors:

Problem	Possible Cause	Measure
No display, no alarm.	Mains or feeding UPS units switched off.	Switch on the mains or feeding UPS units.
	No mains voltage present.	Have mains inspected by qualified electrician.
	Input fuses tripped.	Check and make sure the load capacity within the specification, then replace a good fuse. If the problem persists, contact the responsible customer service representative.
Both mains indicator S1 and S2 do not illuminate, when mains voltage present.	Both input fuses tripped.	Check and make sure the load capacity within the specification, then replace a good fuse. If the problem persists, contact the responsible customer service representative.
Alarm indicator F1 illuminates, acoustic alarm active with 0.5 second sequence.	ATS-16 HV Fault.	Contact the responsible customer service representative.
	EPO	Check all loads and solve (clear) the problem that caused the EPO.
	Overheating	Check and make sure the load capacity within the specification, or decrease ambient temperature (less than 40°C).

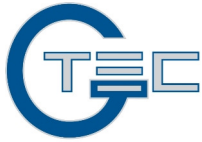

Service Address

U.T.E. Electronic GmbH & Co. KG
Friedrich-Ebert-Str. 112a
58454 Witten

Tel.: 02302-282830 - Email: info@ute.de - Internet: www.ute.de